

TGS 4160 - for the detection of Carbon Dioxide

Features:

- * High selectivity to CO₂
- * Low dependency on humidity
- * Long life

Applications:

- * Air quality control
- * CO₂ control in agricultural applications
- * CO₂ monitoring

The **TGS4160** is a hybrid sensor unit composed of a carbon dioxide sensitive element and a thermistor. A wide range of 350–50,000ppm of carbon dioxide can be detected by TGS4160, making it ideal for usage in a variety of applications.

The CO₂ sensitive element consists of a solid electrolyte formed between two electrodes, together with a printed heater (Pt) substrate. By monitoring the change in electromotive force (EMF) generated between the two electrodes, it is possible to measure CO₂ gas concentration.

Adsorbent (zeolite) is filled between the internal cover and the outer cover for the purpose of reducing the influence of interference gases.

TGS4160 exhibits a linear relationship between Δ EMF and CO₂ gas concentration on a logarithmic scale. The sensor displays good long term stability and shows excellent durability against the effects of high humidity.



The figure below represents typical sensitivity characteristics of TGS4160. The Y-axis is indicated as Δ EMF which is defined as follows:

$$\Delta\text{EMF} = \text{EMF}_1 - \text{EMF}_2$$

where

EMF₁ = EMF in 350 ppm CO₂

EMF₂ = EMF in listed gas concentration

Sensitivity Characteristics:

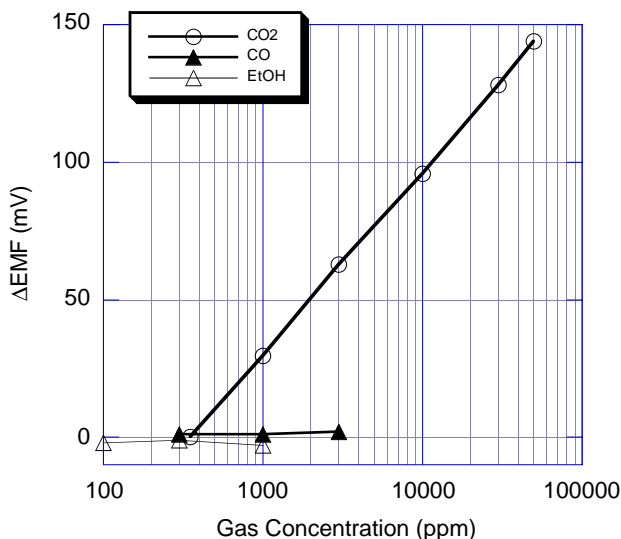

The figure below shows typical humidity dependency for an energized sensor. Again, the Y-axis is indicated as Δ EMF which is defined as follows:

$$\Delta\text{EMF} = \text{EMF}_1 - \text{EMF}_2$$

where

EMF₁ = EMF in 350 ppm CO₂

EMF₂ = EMF in 1000ppm CO₂

Humidity Dependency:

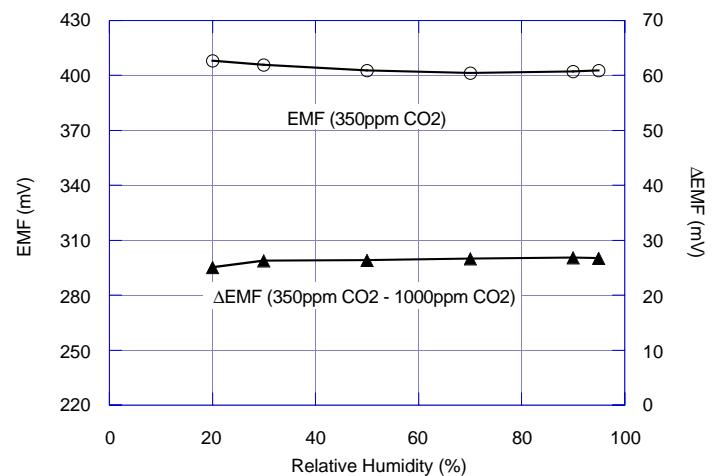

深圳市新世联科技有限公司

Basic Measuring Circuit:

The TGS4160 sensor requires heater voltage (V_H) input. The heater voltage is applied to the integrated heater in order to maintain the sensing element at a specific temperature which is optimal for sensing. Electromotive force (EMF) of the sensor should be measured using a high impedance ($> 100\text{ G}\Omega$) operational amplifier with bias current $< 1\text{ pA}$ (e.g. Texas Instruments' model #TLC271). Since the solid electrolyte type sensor

functions as a kind of battery, the EMF value itself would drift using this basic measuring circuit. However, the change of EMF value (ΔEMF) shows a stable relationship with the change of CO_2 concentration. Therefore, in order to obtain an accurate measurement of CO_2 , a special microprocessor for signal processing should be used with TGS4160. Figaro can provide a special evaluation sensor module (AM-4) for TGS4160.

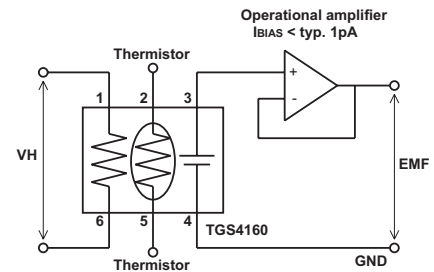

Specifications:

Model number		TGS 4160	
Sensing element type		Solid electrolyte	
Target gases		Carbon dioxide	
Typical detection range		350 ~ 50,000 ppm	
Electrical characteristics under standard test conditions	Heater resistance	R _H	11.5 ± 1.1Ω at room temp.
	Heater current	I _H	approx. 250mA
	Heater power consumption	P _H	approx. 1.25W
	Heater voltage	V _H	5.0 ± 0.2V (DC)
	Electromotive force	EMF	220~490mv in 350ppm CO ₂
	Sensitivity	ΔEMF	44~72mV
Sensor characteristics	Response time	approx. 2 min. (to 90% of final value)	
	Measurement accuracy	approx. ±20% at 1,000ppm CO ₂	
Operating conditions		-10~50°C, 5~95%RH	
Storage conditions		-20~60°C, 5~90%RH (store in moisture proof bag with silica gel)	
Standard test conditions	Test gas conditions	CO ₂ in air at 20±2°C, 65±5%RH	
	Circuit conditions	V _H = 5.0±0.05V DC	
	Conditioning period before test	7 days	

Structure and Dimensions:

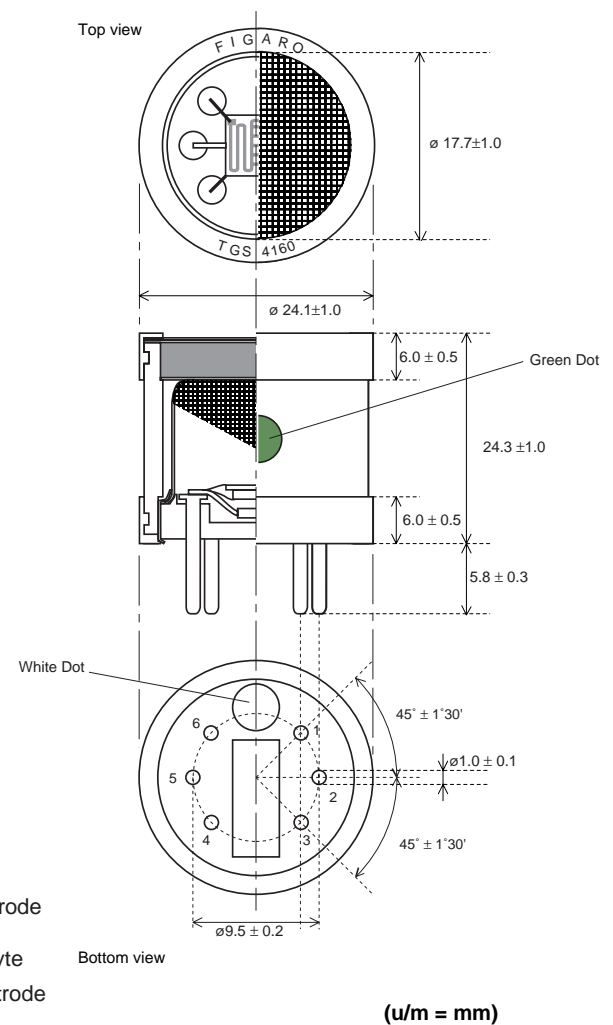

Sensing Element Structure:

Bottom View (Sensor Element)

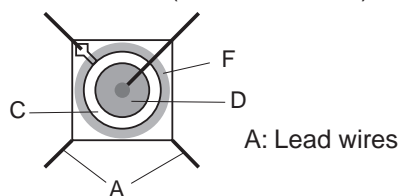

Side view (Sensor Element)

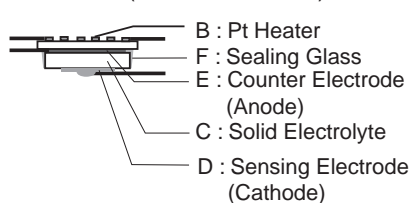

深圳市新世联科技有限公司